

SWEEPMASTER 300

FEATURES:

- Easily adjusted broom down pressure
- Quick view of water tanks
- Advanced hitch/towing package
- Certified roll-over protection structure
- Swing up hood for easy engine access
- Available with 6' or 8' brush

Proven and accepted as #1 leader in the rental sweeping industry, the Lay-Mor Sweepmaster 300 is operator friendly and is easily transported from job to job. There is no need to raise the front wheel off the ground for towing purposes and the tongue can pivot right or left and up and down for faster and easier hook-up. More easily accessible maintenance allows for servicing the unit quicker and simpler than competitive products.



LAYMOR

Contact us at: 903-759-0610 | www.laymor.com

STANDARD EQUIPMENT

- 80 Gallon Sprinkler System
- Two-Post ROPS Canopy
- Rear Fenders
- Positive Neutral Start
- Hydraulic Power Steering
- Hydraulic Drum Rear Towing Brakes
- Mechanical Parking Brake
- Gear Motor Final Drive
- P205 75R14 4-Ply Radials
- Automotive-Style Tow Hitch includes Surge Brakes, Towing Lights and Wiring Harness
- All Polyethylene Brush, all Steel Wire Brush, or 1/2 and 1/2
- Choice of 2" or 2-5/16" ball hitch, or 3" pintle hitches
- Greasable Front Wheel Spindle
- Omaha Orange Paint
- Steel Broom Core
- Front Debris Deflector
- 9 Gallon Fuel Tank w/ Mechanical Gauge
- Cushioned Seat with 2" Retractable Seat Belt & Arm Rests
- Reverse Alarm
- Electric Hour Meter
- Hydraulic Sight Gauge
- Warning Light Package, Engine Oil Pressure, Water Temperature and Alternator
- Engine Protection System
- Hub-Engaged Warning System

TOW PACKAGE

- No jack
- One man operation
- All wheels on the ground during towing
- Minimal tongue weight
- Surge brakes
- Towing lights
- Turn signals

OPTIONS

- Variable Broom Speed
- Dual Broom Drive Motors
- Special Paint Colors
- VISTA Cab™ (factory installed only)
- Heater (VISTA Cab™ only)
- Defroster (VISTA Cab™ only)
- Strobe Light
- Rotating Beacon
- Work Lights
- Emergency Working and Turn Signal Lights

SPECIFICATIONS

- Engine Kubota V1505 diesel, 37 HP
- Broom Size 6-3/8" I.D. x 24" O.D.
- Broom Angle 40° (each way)
- Steering 45° (each way)
- Speed 0 to 7.5 mph
- Machine Weight 6HC 3,000#
- Machine Weight 8HC 3,100#
- Transport Width, Fully Angled 6HC 6'9"
- Transport Width, Fully Angled 8HC 7'10"
- Transport Length, Hitch Down 14'

Sweepmaster 300

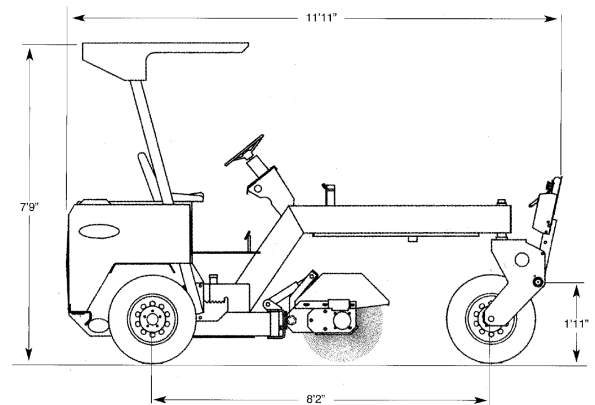

Some items shown represent optional equipment. Due to ongoing engineering improvements, LayMor reserves the right to make changes without notification. LayMor is a subsidiary of Allied Specialty Vehicles.

LAYMOR