

33RTS

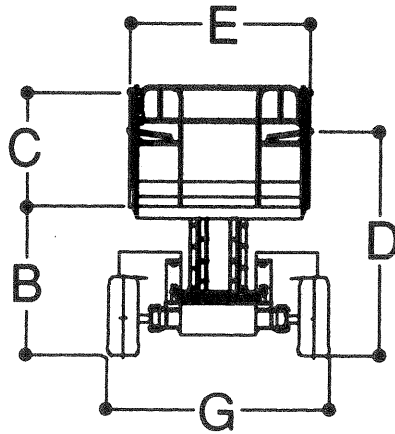
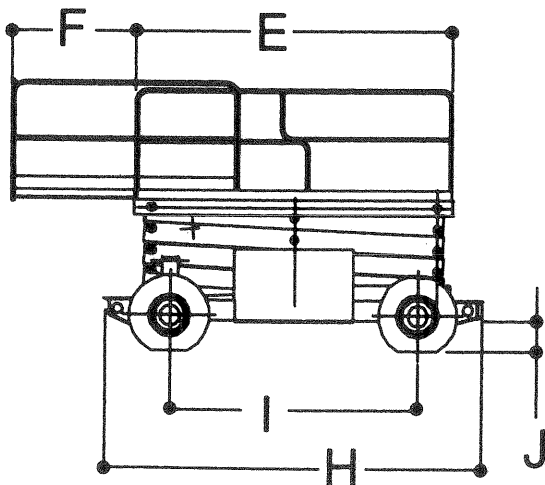
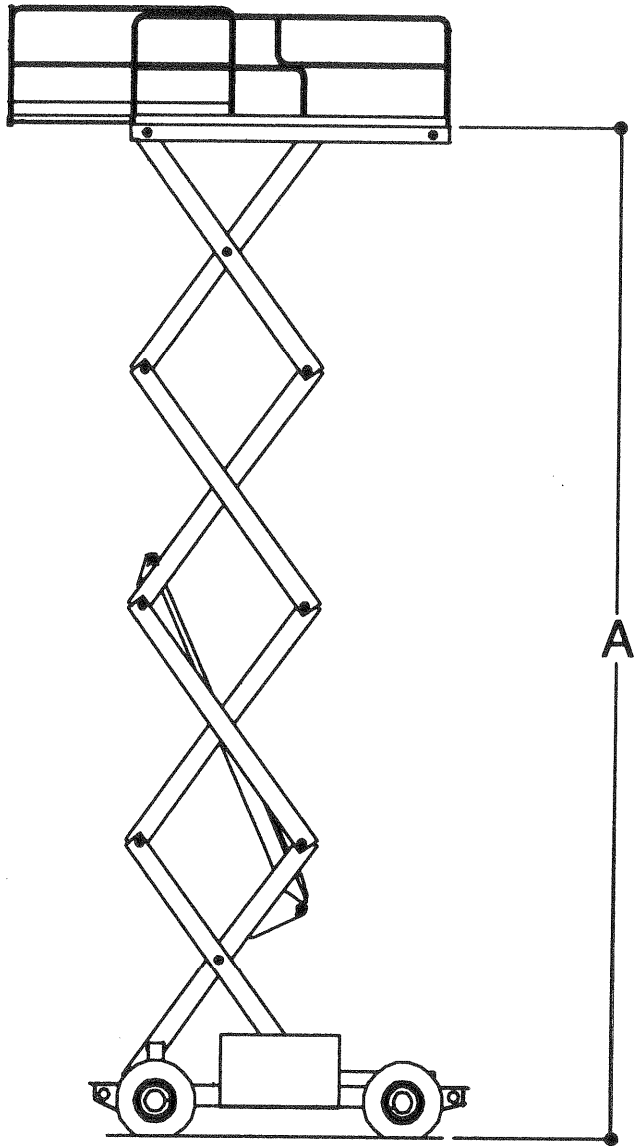

33RTS

DIMENSIONAL DATA

A. Platform Height—Elevated	.33 ft. (10.06 m)
B. Platform Height—Lowered	.5 ft. (1.52 m)
C. Platform Railing Height*	.3 ft. 7.5 in. (1.1 m)
D. Overall Height (Rails Lowered)*	.7 ft. 6 in. (2.29 m)
E. Platform Size	.71 x 126 in. (1.8 x 3.2 m)
F. Platform Extension	.4 ft. (1.22 m)
G. Overall Width	.7 ft. 6 in. (2.29 m)
Overall Width w/ Optional Tires	.7 ft. 7 in. (2.31 m)
H. Overall Length	.12 ft. 5 in. (3.78 m)
I. Wheelbase	.8 ft. 2 in. (2.49 m)
J. Ground Clearance	.12 in. (30 cm)
Platform Capacity	.1,500 lbs. (680 kg)
Platform Capacity w/Optional Platform Extension	.1,250 lbs. (567 kg)
Capacity on Platform Extension	.500 lbs. (230 kg)
Lift/Lower Time	.60/35 sec.
Maximum Drive Height	.Full Height
Gross Vehicle Weight**	.9,200 lbs. (4,173 kg)

CHASSIS

Drive Speed—2WD	.3.5 mph (5.6 kph)
Drive Speed—4WD	.2.8 mph (4.5 kph)
Gradeability—2WD	.35%
Gradeability—4WD	.45%
Turning Radius (Inside)—2WS	.16 ft. 10 in. (5.13 m)
Turning Radius (Inside)—4WS	.5 ft. 6 in. (1.68 m)
Turning Radius (Outside)—2WS	.24 ft. 4 in. (7.67 m)
Turning Radius (Outside)—4WS	.11 ft. 3 in. (3.43 m)
Tire Size/Type	.12 x 16.5 Loader Lug
Axle Oscillation (Optional)	.8 in. (20.4 cm)
Brakes	.Spring Applied Multi-Disc

POWER SOURCE

Dual Fuel Engine	.Ford VSG-413 Water-Cooled, 35 hp (26 kW)
Diesel Engine	.Deutz F2L-1011 Air-Cooled, 28 hp (21 kW)
Fuel Tank Capacity	.15 gal. (56.8 L)
Hydraulic Reservoir	.20 gal. (75.7 L)

* additional 3 in. (8 cm) height with optional platform extension

** certain options or country standards will increase weight