

**FINN****HydroSeeder®****Model T90**

The superior technology behind the T90 HydroSeeder is the result of more than 50 years of extensive FINN research and HydroSeeder manufacturing. Many customers have provided valuable input that shaped the final product. Today, the FINN T90 HydroSeeder offers the ultimate in performance features and operator conveniences that are exactly what you'd expect from the industry leader in hydroseeding quality and innovation.

### **Even Application.**

For ease-of-use, the large loading hatch of the T90 is located at the front of the unit. This allows material to be loaded from the tow vehicle while the operator stands safely on the hitch platform. A uniform mix is of vital importance and the FINN T90 HydroSeeder delivers. The sleek design of the tank provides a smooth slurry flow pattern from the beginning to the end of the load.

### **Rugged & Aggressive.**

The FINN T90 HydroSeeder features a heavy-duty agitator driven by a variable speed, reversible hydraulic motor - with controls both front and rear. The agitator and pump are independently driven, allowing complete mixing of the slurry without pump operation. This significantly enhances

mechanical longevity and flexibility during operation. Outstanding GPM output, piping, and pressure capabilities of the pump result in spray distances of up to 180 feet from the tower gun.

The T90 HydroSeeder boasts a powerful centrifugal slurry pump, driven by an in-line common shaft clutch with no high-cost maintenance couplings, drive belts or hydraulic components. This configuration dramatically increases output and operating pressure.

### **Solid Performance.**

The independent torsion suspension axles of the T90 are equipped with electric brakes for better control. Heavy-duty truck wheels with standard highway-rated tires provide solid stability on uneven terrain.

As the world leader for over 80 years in the design and manufacture of innovative, quality equipment for the green industry, and as the inventor of the HydroSeeder, FINN Corporation is committed to your complete satisfaction.

*Model shown may include optional equipment.*

# FINN HydroSeeder®

## Model T90 with Tier 4F Engine

### T90T TRAILER

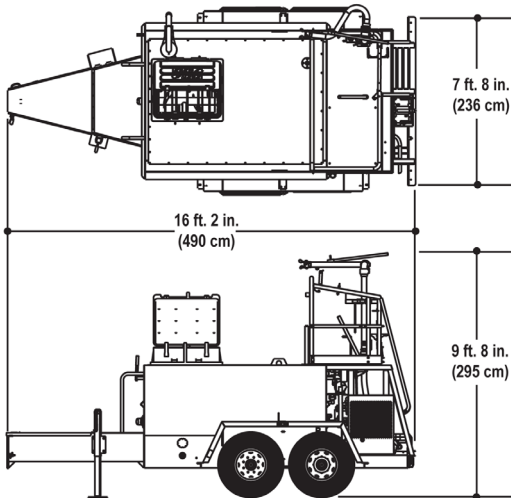

### T90S SKID MOUNT

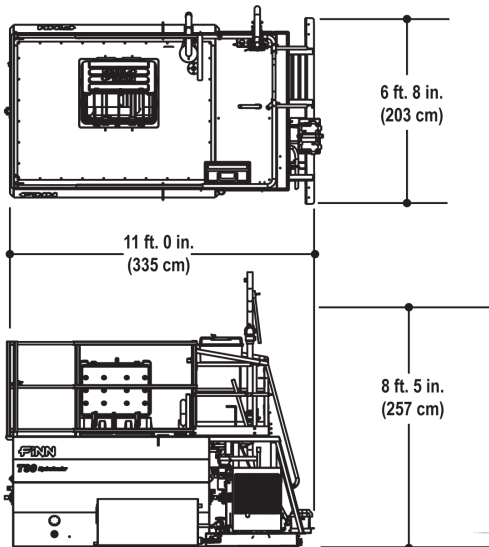

### FINN MODEL T90 TECHNICAL SPECIFICATIONS

POWER .....	Yanmar 3TNV88C-DYEM, 35.1hp (26.2kw), 3 cylinder water cooled diesel engine. Tier 4Final. 1.642L
ENGINE SAFETY.....	Low oil pressure, electronic engine control and monitoring
TANK SIZE .....	940 gallon (3,558 liter) liquid capacity 800 gallon (3,028 liter) working capacity
LOADS PER ACRE¹... ..	3.75
FUEL TANK .....	13.5 gallon (51.1 liter)
CAPACITY	
PUMP .....	Centrifugal 4" x 2" (10 cm x 5 cm) 170 gpm @ 100 psi (689 kPa) (646 lpm @ 7 kg/cm²), 3/4" (1.9 cm) solid clearance, external adjustment
PUMP DRIVE.....	Direct drive with over center clutch, pump drive is independent of agitator operation
AGITATION .....	Mechanical paddle agitation and liquid recirculation
AGITATOR DRIVE.....	Reversible, variable speed hydraulic motor drive (0-100 rpm)
DISCHARGE.....	Up to 180 feet (55 m) from end of discharge tower
DISTANCE	
MAX. MATERIAL.....	2,500 lbs. (1,134 kg) granular solids
CAPACITY	400 lbs. (181 kg) fiber mulch
NOZZLES .....	(1) narrow fan, (1) wide fan, (2) long distance
EMPTY WEIGHT² .....	T90T 5,810 lbs. (2,635 kg) T90S 4,150 lbs. (1,882 kg)
WORKING WEIGHT² .....	T90T 15,115 lbs. (6,856 kg) T90S 13,455 lbs. (6,103 kg)
BRAKES .....	Electric on both axles with breakaway switch
LIGHTS .....	D.O.T. including marker, an identification light and license plate light
TIRES .....	ST225/90D16 bias ply tires, load range E
TRAILER AXLES .....	Tandem 7,000 lbs. (3,176 kg) rubber torsion with fenders.
GVWR.....	15,000 lbs. (6,804 kg)
HITCH WEIGHT .....	Approx. 1,500 lbs. (680 kg)

¹Loads per acre based on an application rate of 1500 lbs. mulch/acre.

²Working weights are approximate and do not include options or stored materials. Working weights assume maximum tank liquid capacity and maximum granular solids material capacity.

FINN Corporation has a policy of continuous product improvement, and reserves the right to change design and specifications without notice.

HydroSeeder® and the FINN Design® Logo are registered trademarks of FINN Corporation.



9281 LeSaint Drive • Fairfield, OH 45014-5457  
Toll Free 800.543.7166 / 513.874.2818  
FINNcorp.com