

IC-100-B

SPECIFICATIONS

BMC® **BRODERSON**®
Manufacturing Corp.

www.BMCcranes.com

GENERAL

	ROTATION	ELEVATION	EXTENSION
Boom Movement	Continuous	0° to 70°	20' (6.1 m)
Boom Speeds	2 RPM.	12 sec.	30 sec.
Weight Total	17,520 lbs. (7,950 kg.)		
Turning Radius	C/L of outside steering wheel: 11' 2" (3.4m) Aisle Width for 90° Turn: 9' 7" (2.92m)		
Gradeability	57% (30°)		

ENGINE

Make	GM	Kubota
Model	3.0 EFI*	V3307 (Tier 4F)
Type	Gas, Fuel Dual	Diesel
Cylinder	4	4
Displacement	181 CID (3L)	199 CID (3.33L)
HP @ Gov. Speed	59HP (44 kW)	74HP (55.4 kW)
Fuel Tank Capacity	17.6 gal. (66.6L)	17.6 gal. (66.6L)

TRANSMISSION

POWERSHIFT TRANSMISSION with 4-speeds in forward & reverse. Provides powershifts at any engine speed in any gear. All shifting is done with a single lever electrical control mounted on the steering column. Multiple-disc clutch packs operated by solenoid valve provide forward, neutral, reverse and speed selection. Equipped with oil cooler and filter. Torque converter has stall ratio of 2.2 : 1.

Transmission Gear	Forward/Reverse	Speed	Drawbar Pull
First	5.72 : 1	4 MPH (6 km/h)	9,500 lbs. (4,300 kg.)
Second	3.23 : 1	7 MPH (11 km/h)	5,500 lbs. (2,500 kg.)
Third	1.77 : 1	13 MPH (21 km/h)	3,000 lbs. (1,300 kg.)
Fourth	1.00 : 1	22 MPH (31 km/h)	1,800 lbs. (800 kg.)

Drawbar pull is calculated based on GM 3.0L gasoline engine.

AXLES

FRONT
Planetary drive/steer axle with 11.625 : 1 axle ratio. Differential is "No-Spin." Axle mounted rigidly to frame.
REAR
2-Wheel Drive:
Axle with 1-1/2° oscillation in either direction.

STEERING

Hydraulic steering unit with cylinders attached to each axle. Rear axle is the primary steer. An electric switch in the operator's compartment is used to select rear-wheel steering, four-wheel round steering or crab steering. Electronic sensors and control box automatically align the steering when a new mode is selected.

BRAKES

Four-wheel hydraulic.
Wet disc brakes are on the front and rear axles.
Parking brake is disc type.

TIRES

2-WHEEL DRIVE
10.00 x 15, 16-ply rating, Highway Type Tread.

CHASSIS

CARGO DECK
53 square feet (5 m²) of deck area. A maximum of 14,000 lb. (6,350 kg) capacity on deck when load is centered over or between axles. A storage box is located in front cargo deck. Steps located on front corners. Heavy deck loads allowed at creep speed below 2 MPH (3.2 km/h) and less than 200 feet (61 m) in 30 minutes.

OUTRIGGERS
Four hydraulic outriggers of box beam construction. Independent controls for each outrigger. Each cylinder equipped with direct-connected holding valves.
Outrigger pad dimension: 9 inches (23 cm.) x 12 inches (30 cm.)

LIFTING RINGS
Lifting rings at each corner of cargo deck so sling can be attached for lifting crane.

OPERATOR COMPARTMENT

OPERATOR'S CONTROL STATION provides one-position access to all operating functions. Includes adjustable operator's seat, retracting seat belt, fire extinguisher and bubble level.

ELECTRICAL (12-VOLT SYSTEM)

INSTRUMENT PACKAGE
Includes fuel gauge and hourmeter. Also included are warning lights for low oil and transmission pressure, turn signal, high beams, hazard lights, parking brake, hydraulic oil temperature, battery, check engine, stop engine, coolant temperature, outriggers.

LIGHTING PACKAGE
Headlights with Hi and Low beams, back-up lights, integral tail, brake, front and rear turn signals and emergency flasher switch at operator's station. 12V horn actuated by button on shifting control.

BACK-UP ALARM
Provides pulsating sound from 102 dB alarm when transmission is in reverse. Conforms to SAE J994b.

OUTRIGGER ALARM SYSTEM
Two-tone alarm is activated when "outrigger down" controls are operated.

HYDRAULIC

TANDEM PUMP, direct-driven by engine crankshaft, rated at 16 & 32 GPM at rated RPM (61 L/min & 121 L/min). Hydraulic oil tank capacity of 25 gallons (95 L).

BOOM ASSEMBLY

THREE-SECTION BOOM ASSEMBLY equipped with bearing pads, double-acting hydraulic cylinders with direct-connected holding valves & boom angle indicator on each side of boom.

BOOM ROTATION
Heavy-duty ball bearing rotation gear with external teeth. Rotation is powered by hydraulic motor and worm gear drive.

BOOM HOIST:
Turret mounted planetary gear hoist hydraulically powered with a bare-drum line pull of 11,500 lbs (5,200 kg) at a speed of 100 FPM (30.5 m/min). Includes down-haul weight, swivel hook & sheave block for 2-part line and 140 ft (43 m) of 9/16" (14 mm) hoist rope.

ANTI-TWO-BLOCK DEVICE
Prevents damage to hoist rope and/or crane components from pulling load hook against tip.

SHEAVE BLOCK, TWO-PART
Single sheave block for 2-part line requirements.

RATED CAPACITY LIMITER
Warns operator of impending overload with audible and visual signals. Prevents overload by stopping boom functions that cause overloads.

DRUM ROTATION INDICATOR
Provides visible feedback to operator when hoist drum is rotating.



Capacity

20,000 lbs (9,072 kg)

Sheave Height

59' 4" (18.085 m)
(with boom extension)

Horizontal Reach

43' (13.1 m)
(with boom extension)

Height

7' 5" (2.26 m)

Width

6' 6" (2 m)

IC-100-B

SPECIFICATIONS

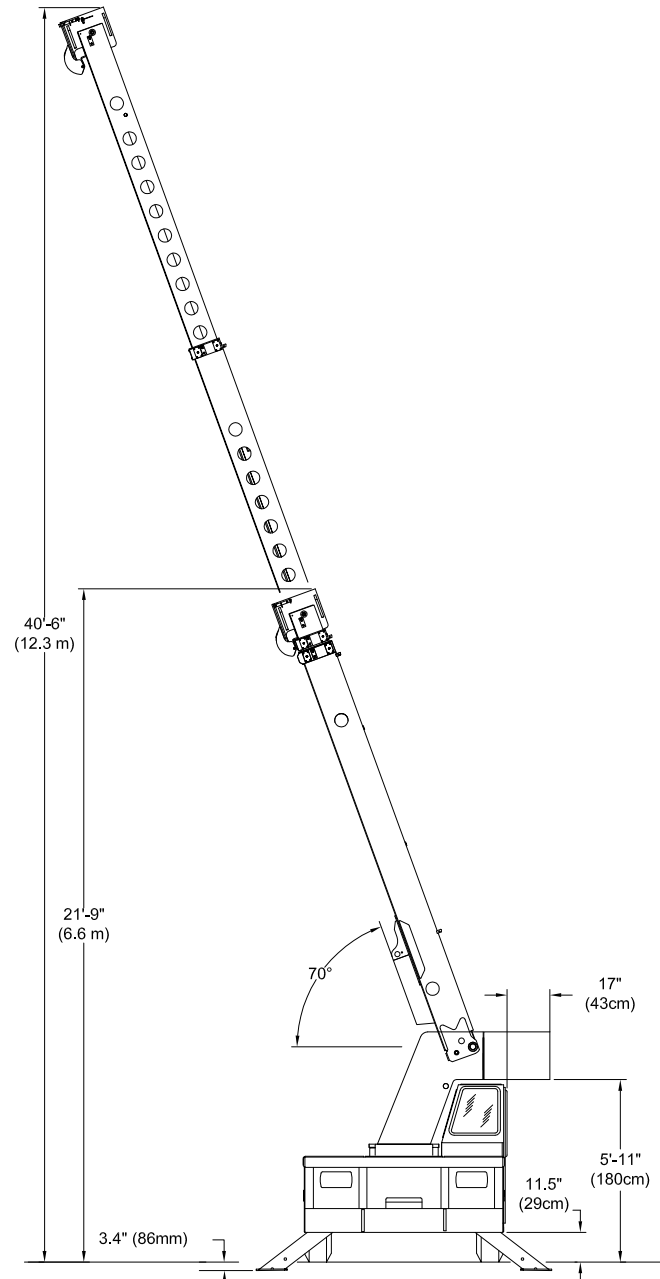
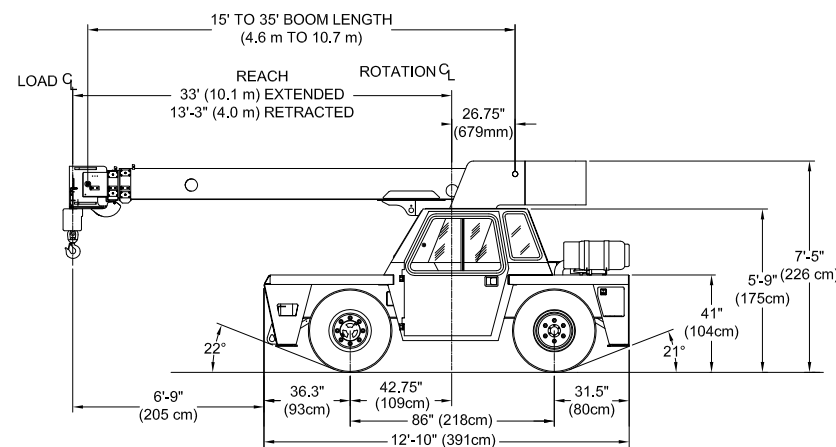
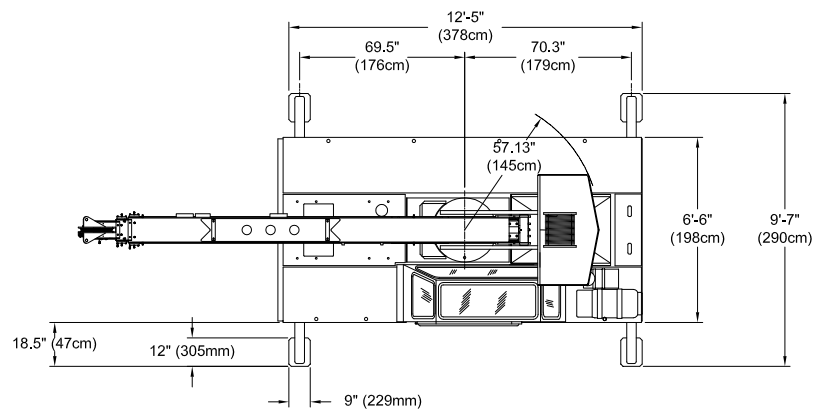

BMC[®] BRODERSON[®]

Manufacturing Corp.

IC-100-B

SPECIFICATIONS

CONSULT THE IC-100-A ENGINEERING SPEC FOR ADDITIONAL INFORMATION.

Main Features

RATED CAPACITY LIMITER
Standard

CAPACITY ON OUTRIGGERS
20,000 lbs. (9,000 kg)

PICK AND CARRY CAPACITY
up to 11,200 lbs. (5,091 kg)

HEIGHT
7' 5" (2.26 m)

WIDTH
6' 6" (2.0 m)

BOOM ROTATION
360° Continuous

SHEAVE HEIGHT
up to 49' 4" (15 m)

HORIZONTAL REACH
up to 33' 0" (10 m)

4-WHEEL STEER
Standard

4-WHEEL DRIVE
Optional

POWERSHIFT TRANSMISSION
Standard

FULLY HYDRAULIC CONTROLS FOR SMOOTH, PRECISE OPERATIONS

INDEPENDENT OUTRIGGER CONTROLS

ENGINE OPTIONS

Spark Arrester Muffler
Installed in addition to standard muffler

Catalytic Converter
Reduces engine emissions

Engine Heater
Coolant heater installed to circulate warm water through engine. Plugs into 120 volt AC, 1,500 watts

TIRE OPTIONS

Mining & Industrial
11 x 15, 120 lbs. (57 kg.)

Mining & Industrial Non-Marking
10 x 15, 120 lbs. (57 kg.)

Solid Rubber Tires
8.25 x 15

Foam Filled Tires
All four 400 lbs. (181 kg.)

Spare Tire & Wheel
Mounted

CHASSIS

Auxiliary Winch
Mounted behind front bumper, hydraulically driven with controls.

Pintle Hook:
Pintle Hook, Rear
Pintle Hook, Front

Rearview Mirrors
One mounted on right & left-hand deck stake

OPERATOR COMPARTMENT

Operator Guard
Tubular steel weldment with heavy expanded steel mesh top section.

All-Weather Cab
Rigid-mounted canopy section & removable hinged door. Includes heater, electric windshield wiper, one sliding glass window in the door & one in the right

Options

side of canopy. Defroster fan & dome light included.

Cab Heater
Heater with two-speed fan for units without All Weather Cab.

Windshield Washer
Includes reservoir pump and nozzle.

Floor Mat
Vinyl mat with foam backing.

Deluxe Seat
Provides additional operator comfort.

Noise Reduction Kit
Includes floor mat, control valve and side panels of foam backed vinyl for noise reduction.

Air Conditioning
Air Conditioner with R134 coolant.

ELECTRICAL

Strobe Lights
Yellow strobe light mounted on each side of turret weight box.

Boom Work Lights
One work light mounted to boom to light boom tip and one work light mounted to turret to light ground under boom tip.

Work Lights-Rear
Two work lights recessed in rear bumper.

RCL Light Bar
3 color light bar for external indication of load status

BOOM ATTACHMENTS

Boom Extension
10ft. (3m), Boom stowable.

Boom Extension
10ft. (3m), Offsettable.
Same as above item, except boom extension is offsettable to 3 different positions; 0° (inline), 15° and 30° offset.

Searcher Hook
Nose Mount

Broderson Cranes are manufactured to ISO 9001:2015 certified standards and have a market leading reputation for quality and reliability. Broderson Cranes are engineered for operating efficiency and are easy to operate and maintain.

An extensive network of full-service dealers offer parts and service support by factory-trained technicians.

For additional options or special equipment not listed, please consult your dealer salesperson or contact Broderson Manufacturing Corp.

BRODERSON[®]
Manufacturing Corp.
14741 West 106th Street
Lenexa, KS 66215 USA

(913) 888-0606
www.BMCcranes.com

Dimensions and values shown are for reference purposes only. Specifications subject to change.

