

## **IC-200-3J** **Industrial Crane**

The IC-200 is a self-propelled Industrial crane designed for material handling and installation, and equipment maintenance. It includes a 4-section proportional hydraulically extended boom.

### **Capacity**

30,000 lbs. (13,600 kg)

### **Sheave Height**

73' 8" (22.5 m)  
(with boom extension)

### **Horizontal Reach**

66' (20.1 m)  
(with boom extension)

### **Height**

8' (2.44 m)

### **Width**

7' 10.5" (2.4 m)



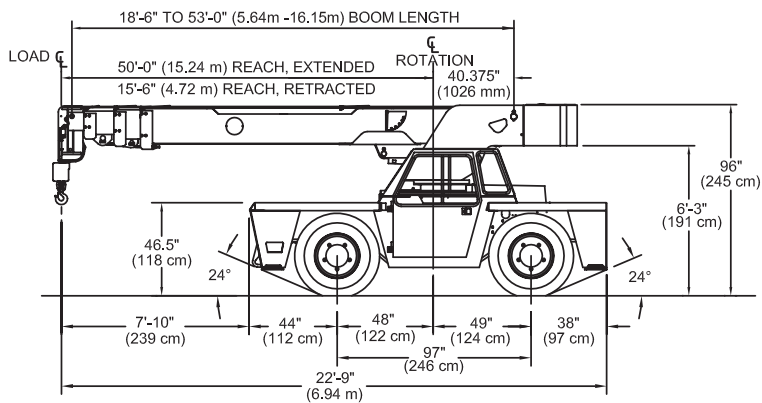
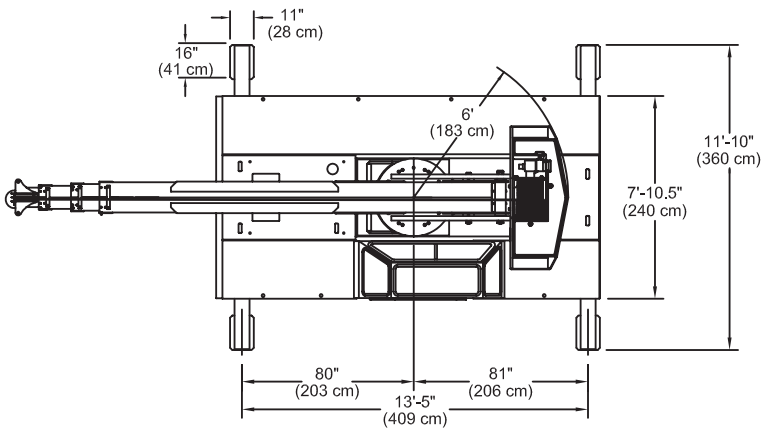
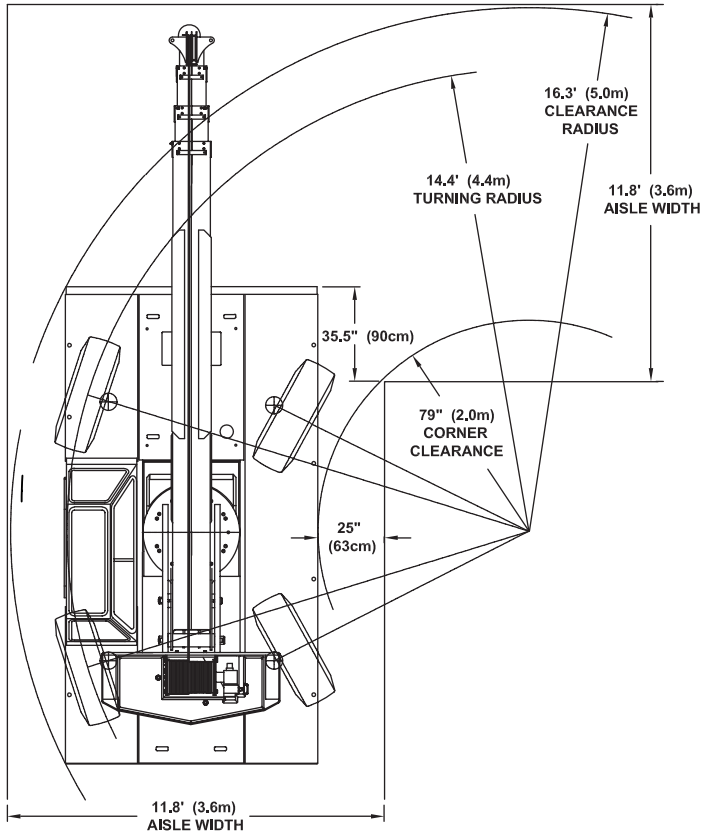

58'-8" (17.9 m) EXTENDED  
25'-8" (7.8m) RETRACTED

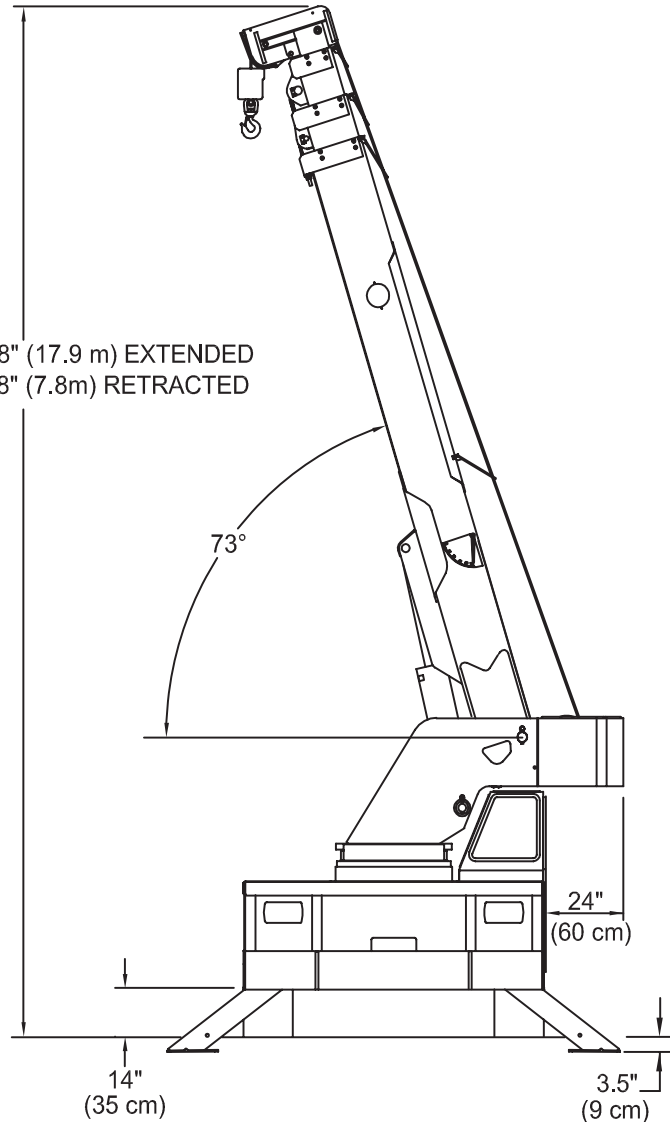

# IC-200-3J

## GENERAL SPECIFICATIONS



### GENERAL

	ROTATION	ELEVATION	EXTENSION
Boom Movement	Continuous	0° to 73°	34'6" (10.5m)
Boom Speeds	1.8 RPM	20 sec.	50 sec.
Weight Total	31,080 lbs. (14,110 kg.)		
Gradeability	54% (28°)		
Turning Radius	14' 5" (4.42m)		

### ENGINE

Make	GM	Cummins
Model	4.3L V6	QSF3.8L US EPA T4F
Type	Dual fuel with catalytic converter	Turbo-Diesel
Cylinder	6	4
Displacement	4.3L	3.8L
HP @ Gov. Speed	93HP (69kW)	120HP (89kW)

### TRANSMISSION

**POWERSHIFT TRANSMISSION** with 4-speeds forward and reverse. Provides powershifts at any engine speed in any gear. All shifting is done with a single lever electrical control mounted on the steering column. Equipped with torque converter and transmission oil cooler. Torque converter has stall ratio of 2.2:1.

#### GEAR RATIO:

First - 5.72:1, Second - 3.23:1, Third - 1.77:1, Fourth - 1.00:1

#### FRONT

Planetary drive/steer front axle with 15.78 to 1.0 ratio. Differential equipped with "limited slip" feature. Front axle mounted rigidly to frame.

TRANS. GEAR	SPEED	DRAWBAR PULL*
First	3 MPH	17,000*
Second	5 MPH	8,900*
Third	10 MPH	5,100*
Fourth	18 MPH	2,700*

\*Drawbar pull is calculated for GM 4.3L engine.

#### REAR

##### Standard (2-Wheel Drive):

Steering axle with 1-1/2 degree oscillation in either direction.

##### Optional (4-Wheel Drive):

Planetary drive/steer axle with 24.98 to 1.0 ratio. Differential is not "limited slip" in rear axle. 1-1/2 degree oscillation in either direction. Axle ratio compatible with 4-wheel drive transmission output for front axle match. Transmission equipped with electrohydraulic control for shifting between 2-wheel drive and 4-wheel drive.

### AXLES

Full hydraulic steering unit with two 3-inch (7.6 cm) cylinders attached to each axle. Allows limited steering when engine is not running. A switch on the control panel is used to select rear-wheel steering, four-wheel steering or crab steering. Electronic sensors and control box automatically align the steering when a new mode is selected.

### STEERING

**Service:** Split-system, 4-wheel hydraulic-boosted multiple plate wet disc brakes.

**Parking:** Hand lever actuated disc-type parking brake on transmission.

### BRAKES

### TIRES

15x22.5, 16-ply rating.

### OPERATOR COMPARTMENT

Provides one-position access to all chassis & crane functions. Includes adjustable operator's seat, retracting seat belts, fire extinguisher & bubble level.

### CHASSIS

#### CARGO DECK

66 square feet (6 m<sup>2</sup>) of deck area. 17,000 lbs (7,700 kg) capacity on deck when load is centered over or between axles. Steps located on front corners.

#### LIFTING RINGS

Lifting rings at each corner of cargo deck so sling can be attached for lifting crane.

#### OUTRIGGERS

Four hydraulic outriggers of box beam construction with direct connected holding valves. Independent controls for each outrigger.

**Outrigger pad dimension: 11" x 16" (28cm x 41cm).**

#### HEADLIGHT & TAILLIGHT GRILLES

Welded steel protective grilles for headlights and taillights.

#### ACCESSORY STORAGE BOX

Storage box is 14" (35cm) deep x 10-1/2" (26cm) long x 36-1/2" (93cm) wide, located in front cargo deck.

#### LIGHTING PACKAGE

One pair headlights with high and low beams, tail, brake and turn signal lights and back-up lights in rear, front turn signals and emergency flasher switch at operator's station.

#### DISPLAY

Fuel gauge and hourmeter records hours only during actual engine operations. Also includes warning lights for low oil and transmission pressure, check engine, high coolant and transmission temperature, turn signals, high beams, hazard lights, parking brake and four-wheel drive.

#### BACK-UP ALARM

Provides pulsating sound when transmission is in reverse.

#### OUTRIGGER ALARM SYSTEM

Two-tone alarm is activated when "outrigger down" controls are operated.

### ELECTRICAL (12-VOLT SYSTEM)

### HYDRAULIC

**TANDEM PUMP** direct-driven by engine crankshaft, rated at 29 GPM (110 L/min) and 34 GPM (129 L/min) at rated RPM. Hydraulic oil tank capacity of 54 gallons (204 L)..

#### FOUR-SECTION BOOM ASSEMBLY

equipped with bearing pads, double-acting hydraulic cylinders with direct-connected holding valves and boom angle indicator on each side of boom.

#### BOOM ROTATION

Heavy-duty ball bearing rotation gear with external teeth. Rotation is powered by hydraulic motor and worm gear drive.

#### BOOM HOIST

Turret mounted planetary gear hoist hydraulically powered with a bare drum line pull of 10,000 lbs. (4536 kg) at a line speed of 100 FPM (30 m/min). Includes downhaul weight, swivel hook and sheave block for 4-part line.

#### ANTI-TWO-BLOCK DEVICE

Prevents damage to hoist rope and/or crane components from pulling load hook against tip.

#### SHEAVE BLOCK, FOUR PART LINE

Double sheave block for 4-part line requirements.

#### RATED CAPACITY LIMITER

Warns operator of impending overload with audible & visual signals. Prevents overload by stopping boom functions that cause overloads.

#### DRUM ROTATION INDICATOR

Tactile feedback to operator when drum is rotating.

### OTHER

Shorter boom model IC-200-2J available.

CONSULT THE IC-200-J ENGINEERING SPEC FOR ADDITIONAL INFORMATION.

## **Main Features**

**RATED CAPACITY LIMITER**  
Standard

**CAPACITY ON OUTRIGGERS**  
30,000 lbs. (13,600 kg)

**PICK AND CARRY CAPACITY**  
up to 17,000 lbs. (7,711 kg)

**HEIGHT**  
8' (2.45 m)

**WIDTH**  
7' 10.5" (2.4 m)

**BOOM ROTATION**  
360° Continuous

**SHEAVE HEIGHT**  
up to 73'10" (22.5 m)

**HORIZONTAL REACH**  
up to 66' (20.1 m)

**FOUR-WHEEL STEER**  
Standard

**FOUR-WHEEL DRIVE**  
Optional

**POWERSHIFT TRANSMISSION**  
Standard

**FULLY HYDRAULIC CONTROLS FOR  
SMOOTH, PRECISE OPERATIONS**

**INDEPENDENT OUTRIGGER  
CONTROLS**

**DIESEL OR DUAL FUEL ENGINES  
AVAILABLE**

## **ENGINE**

### **Spark Arrester Muffler**

Installed in addition to standard muffler.  
(Dual Fuel engine only.)

### **Engine Heater**

Engine coolant heater installed to circulate warm water through engine, plugs into 120 volt AC.

## **AXLE & STEERING**

4-Wheel Steer & 2-Wheel Drive  
4-Wheel Steer & 4-Wheel Drive

## **TIRE**

Non Marking Tires  
Foam Filling of Tires  
Spare Tire & Wheel

## **CHASSIS**

**Auxiliary Winch**  
Mounted behind the front bumper, hydraulically driven with control in operator's console.

### **Pintle Hook**

Rear and Front

### **Rearview Mirrors**

One mounted on right-hand deck stake and one mounted on left-hand deck stake.

## **OPERATOR COMPARTMENT**

### **Operator Guard**

Tubular steel weldment with heavy expanded steel mesh top section for units without All Weather Cabs.

### **All Weather Cab**

Rigid-mounted canopy section and removable hinged door. Includes heater, electric windshield wiper, one sliding glass window in the door, & one in the right side of the canopy. Defroster fan & dome light included.

### **Cab Heater Only**

Heater with two-speed fan for units without All Weather Cab.

## **Options**

### **Windshield Washer**

Includes reservoir, pump & nozzle.

### **Floor Mat**

Vinyl mat with foam backing.

### **Operator Suspension Seat**

### **Noise Reduction Kit**

Includes floor mat, control valve cover and side panels of foam backed vinyl for noise reduction.

### **Air Conditioning**

Air Conditioner w/134 coolant.

## **ELECTRICAL**

### **Strobe Lights**

Yellow strobe light mounted on each side of turret weight box.

### **Boom Work Lights**

One work light mounted to boom to light boom tip and one work light mounted to turret to light ground under boom tip.

### **Work Lights - Rear**

Two work lights recessed in rear bumper

### **RCL Light Bar**

3 color light bar for external indication of load status

## **BOOM ATTACHMENTS**

### **Boom Extension**

16 foot (5 m), offsettable

### **Sheave Block**

Two-Part Line

### **Searcher Hook**

Nose Mount 5,000 lb (2,268 kg) capacity hook bracket

Broderson Cranes are manufactured to ISO 9001:2015 certified standards and have a market leading reputation for quality and reliability. Broderson Cranes are engineered for operating efficiency and are easy to operate and maintain.

An extensive network of full-service dealers offer parts and service support by factory-trained technicians.

For additional options or special equipment not listed, please consult your dealer salesperson or contact Broderson Manufacturing Corp.

**BRODERSON**®  
**Manufacturing Corp.**  
14741 West 106th Street  
Lenexa, KS 66215 USA

(913) 888-0606  
[www.BMCcranes.com](http://www.BMCcranes.com)

Dimensions and values shown are for reference purposes only. Specifications subject to change.



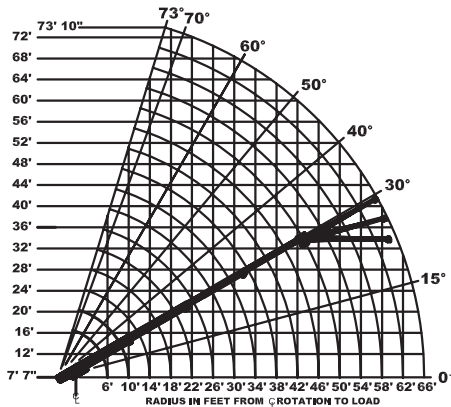

USE SINGLE PART  
LOAD LINE FOR  
LOADS TO 7500  
LBS. (WT. 125 LBS.)

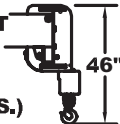

USE TWO PART  
LOAD LINE FOR  
LOADS TO 15000  
LBS. (WT. 200 LBS.)

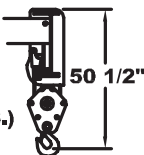

USE FOUR PART  
LOAD LINE FOR  
LOADS TO 30000  
LBS. (WT. 210 LBS.)

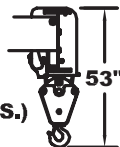

CAPACITIES IN POUNDS FOR OPERATION ON FIRM LEVEL SURFACE								
LOAD RADIUS FEET	MAIN BOOM ONLY				BOOM EXTENSION			
	ON RUBBER		ON OUTRIGGERS		ON RUBBER		ON OUTRIGGERS	
	360°	FRONT	360°	FRONT	360°	FRONT	360°	FRONT
6	16000	16400	30000	30000	----	----	----	----
8	12500	13000	22400	22400	----	----	----	----
10	10000	10500	18500	18500	7500	7500	7500	7500
12	8050	8700	15700	15700	7500	7500	7500	7500
14	6500	7200	13500	13500	7500	7500	7500	7500
16	5300	6200	10800	10800	6150	7500	7500	7500
18	4450	5400	9550	9550	5000	6450	7500	7500
20	3700	4700	8550	8550	4200	5400	7500	7500
22	3150	4200	7700	7700	3550	4650	6850	6850
24	2650	3700	6950	6950	3050	4000	6250	6250
26	2300	3200	6300	6350	2650	3500	5750	5750
28	1950	2800	5550	5800	2300	3100	5300	5300
30	1700	2450	4800	5300	2000	2700	4900	4900
32	1450	2150	4200	4900	1700	2400	4550	4550
34	1250	1850	3700	4500	1500	2100	4250	4250
38	900	1300	2950	3850	1150	1650	3500	3750
42	650	950	2400	3350	850	1300	2950	3350
46	400	650	1850	2900	600	1050	2450	2950
50	0	550	1750	2500	400	800	2050	2600
54	----	----	----	----	0	600	1700	2300
58	----	----	----	----	0	400	1350	2000
62	----	----	----	----	0	300	1150	1750
66	----	----	----	----	0	0	900	1500
BOOM EXT. ANGLE	BOOM EXTENSION - STRAIGHT OR OFFSET							
	MAIN BOOM ANGLE							
	0°	15°	30°	40°	50°	60°	70°	
0°	3000	3100	3450	3900	4650	6000	7500	
15°	---	3000	3000	3000	3000	3700	5000	
30°	---	---	2500	2500	2600	3100	3800	

Boom extension deduct: 400 lbs. when stowed on main boom.

Deck load capacity 17,000 lbs, with empty boom retracted over front, deck load centered to rear of front axle, less than 2mph, 200ft. Max in 30 minutes on smooth pavement.

LOAD RADIUS IS THE HORIZONTAL DISTANCE FROM THE CENTER OF ROTATION OF THE UNLOADED CRANE TO THE VERTICAL LOAD LINE WITH THE LOAD APPLIED.

EXCEEDING CAPACITY RATINGS OR APPLYING SIDE LOADS TO THE BOOM OR BOOM EXTENSION IS MISUSE, HAZARDOUS, AND VOIDS WARRANTY.

**CAUTION:** BOOM EXTENSION LOADS MUST NOT EXCEED MAIN BOOM CAPACITY. DO NOT PICK AND CARRY WITH BOOM EXTENSION DEPLOYED.

ARE 85% OF TIPPING LOADS. CAPACITIES ON RUBBER ARE 75% OF TIPPING LOADS. CAPACITIES ON IN & DOWN OUTRIGGERS ARE LESS THAN 85% OF TIPPING LOADS. CAPACITIES BELOW BOLD LINE ARE LIMITED BY TIPPING. OTHER CAPACITIES ARE LIMITED BY STRUCTURAL OR HYDRAULIC CAPABILITY.

## Load Chart Metric

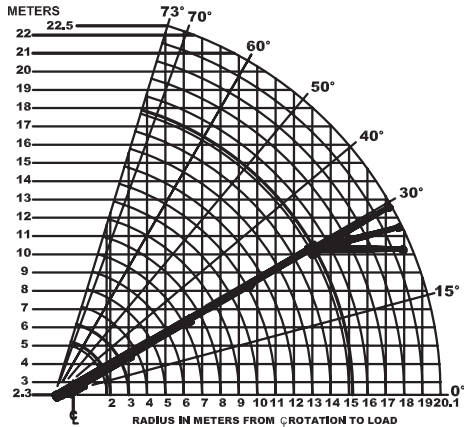

USE SINGLE PART  
LOAD LINE FOR  
LOADS TO 3400 kg  
(WT. 57 kg)

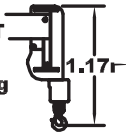

USE TWO PART  
LOAD LINE FOR  
LOADS TO 6800  
kg (WT. 91 kg)

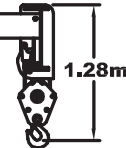

USE FOUR PART  
LOAD LINE FOR  
LOADS TO 13600  
kg (WT. 96 kg)

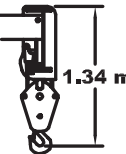

CAPACITIES IN KILOGRAMS FOR OPERATION ON FIRM LEVEL SURFACE								
LOAD RADIUS METERS	MAIN BOOM ONLY				BOOM EXTENSION			
	ON RUBBER		ON OUTRIGGERS		ON RUBBER		ON OUTRIGGERS	
	360°	FRONT	360°	FRONT	360°	FRONT	360°	FRONT
1.8	7260	7440	13600	13600	----	----	----	----
2.0	6730	6940	12100	12100	----	----	----	----
2.5	5550	5780	9970	9970	----	----	----	----
3.0	4610	4840	8510	8510	3400	3400	3400	3400
3.5	3860	4140	7410	7410	3400	3400	3400	3400
4.0	3230	3540	6560	6560	3400	3400	3400	3400
4.5	2720	3070	5670	5670	3200	3400	3400	3400
5.0	2320	2730	4750	4750	2680	3300	3400	3400
5.5	2010	2440	4320	4320	2260	2910	3400	3400
6.0	1720	2170	3940	3940	1950	2520	3400	3400
7.0	1310	1790	3320	3320	1490	1960	2970	2970
8.0	1020	1420	2810	2850	1180	1560	2580	2580
9.0	800	1140	2260	2450	940	1260	2260	2270
10.0	620	920	1810	2150	730	1030	2010	2000
11.0	480	700	1480	1870	590	830	1760	1800
12.0	370	530	1250	1660	470	690	1500	1640
13.0	270	410	1050	1480	360	570	1300	1490
14.5	120	260	790	1240	230	430	1040	1270
15.3	0	250	790	1130	180	360	930	1180
17.0	----	----	----	----	0	240	700	980
18.0	----	----	----	----	0	160	590	870
19.0	----	----	----	----	0	130	510	780
20.1	----	----	----	----	0	0	410	680
BOOM EXT. ANGLE	BOOM EXTENSION - STRAIGHT OR OFFSET							
	MAIN BOOM ANGLE							
	0°	15°	30°	40°	50°	60°	70°	
0°	1360	1400	1560	1770	2110	2720	3400	
15°	----	1360	1360	60	1360	1680	2270	
30°	----	----	1130	1130	1180	1410	1720	

Boom extension deduct: 182 kgs. when stowed on main boom.

Deck load capacity 7,700 kg., with empty boom retracted over front, deck load centered to rear of front axle. Max in 30 minutes on smooth pavement.

LOAD RADIUS IS THE HORIZONTAL DISTANCE FROM THE CENTER OF ROTATION OF THE UNLOADED CRANE TO THE VERTICAL LOAD LINE WITH THE LOAD APPLIED.

EXCEEDING CAPACITY RATINGS OR APPLYING SIDE LOADS TO THE BOOM OR BOOM EXTENSION IS MISUSE, HAZARDOUS, AND VOIDS WARRANTY.

**CAUTION:** BOOM EXTENSION LOADS MUST NOT EXCEED MAIN BOOM CAPACITY. DO NOT PICK AND CARRY WITH BOOM EXTENSION DEPLOYED.

ARE 85% OF TIPPING LOADS. CAPACITIES ON RUBBER ARE 75% OF TIPPING LOADS. CAPACITIES ON IN & DOWN OUTRIGGERS ARE LESS THAN 85% OF TIPPING LOADS. CAPACITIES BELOW BOLD LINE ARE LIMITED BY TIPPING. OTHER CAPACITIES ARE LIMITED BY STRUCTURAL OR HYDRAULIC CAPABILITY.