

Internal Combustion Pneumatic Tire Lift Trucks

Capacity: 3,000-7,000 lb





Our 3,000-7,000 lb capacity pneumatic tire lift trucks have an engineered design that delivers top horsepower and performance for exceptional productivity.

P3000-P7000 Series

Whether you're handling industrial materials or shipping products on a tight schedule, our internal combustion pneumatic tire lift trucks work long and hard to get the job done.

Each of the models exceeds stringent Environmental Protection Agency (EPA) standards for reducing carbon monoxide (CO), hydrocarbons (HC) and nitrogen oxide (NOx) emissions, while delivering the power you need for work-horse performance. Operator comfort features, including a full suspension seat, are standard, and many high-performance packages are available to tailor your lift truck to specific application requirements. From the manufacturing headquarters in Houston, Texas, using ISO 14001 certified and independently audited quality control procedures, these lift trucks provide excellent long-term value and come with turnkey support from the industry's most trusted dealer network.

Model	Fuel Type	Rated Capacity (lb)	Engine Displacement (liters) Gasoline/Diesel
P3000	Gas/LP	3,000	2.1 / –
P3500	Gas/LP	3,500	2.1 / –
PC4000	Gas/LP	4,000	2.1 / –
P4000	Gas/LP/Diesel	4,000	2.5 / 3.3
P5000	Gas/LP/Diesel	5,000	2.5 / 3.3
P5500	Gas/LP/Diesel	5,500	2.5 / 3.3
P6000	Gas/LP/Diesel	6,000	2.5 / 3.3
P6500	Gas/LP/Diesel	6,500	2.5 / 3.3
P7000	Gas/LP/Diesel	7,000	2.5 / 3.3



Quality



Heavy-duty applications require heavy-duty machinery. Our trucks are built for powerful, rugged applications, making operator comfort and convenience all the more important.

Operator Efficiency And Comfort

A clean, unobstructed work environment enables the operator to perform more efficiently. A generous floor area enhances operator mobility. The open-step entry with slip-resistant steel plates and an easy-to-reach elongated grab bar help facilitate cab access.

A seat-side convenience tray provides the operator with an easy to reach storage location. The convenience tray includes a metal clip board holder, cup holder, pen/pencil compartment and miscellaneous items compartment.

Added Operator Protection

The advanced Cat Lift Trucks operator Presence Detection System (PDS) keeps your operator informed. When your operator leaves the normal seated operating position, the following occurs:

the parking brake

When your operator returns to the normal seated operating position, a buzzer will sound as a reminder to fasten the seat belt.



Quietly Smooth Transmission

To reduce noise and vibration, the transmission uses helical gears and a full-floating powertrain that isolates the engine and transmission from the frame and operator compartment. In addition, a hydraulic accumulator promotes smooth starts and direction changes, fostering operator efficiency while minimizing vibration.

Full-Suspension Seat And Tilt Steering

Comfort increases productivity. A full-suspension seat allows your operator to move in just about any direction, with forward, back, weight and lumbar adjustments. The supportive design promotes comfort by resisting shock and vibration.

A tilt steering feature offers infinite adjustability within a 12-degree range of movement to comfortably accommodate most operators. A separate lever moves the column fully forward to provide easy access to the engine compartment. Afterwards, the memory recall will automatically return the column to your operator's preferred position.

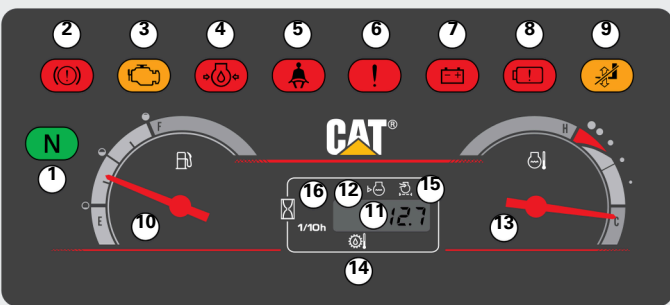

Standard Indicator Package

The instrument panel tilts with the steer column, keeping it in the line of sight of the operator. A standard indicator package keeps the operator informed of operating conditions and includes the items to the right.

- 1 Neutral indicator
- 2 Parking brake reminder/brake fluid level
- 3 Check engine
- 4 Engine oil pressure
- 5 Seat belt warning
- 6 System warning
- 7 Alternator (battery charging)
- 8 Low LP fuel warning (standard for LP fuel only) glow plug (diesel only)
- 9 Mast/auxillary hydraulic function interlock
- 10 Fuel gauge (gasoline and diesel only)
- 11 Hour meter/diagnostic codes
- 12 Radiator level (option)
- 13 Coolant temperature level
- 14 Transmission oil temperature
- 15 Clogged air cleaner (option)
- 16 Water indicator (diesel only) (indicator not shown)

Reliability



The powerful engine runs smoothly and quietly. Our trucks include a durable frame, powerful masts with dependable performance and a highly-efficient fuel system.

Prolonging Equipment Life

With advanced on-board diagnostics, it's easier than ever to keep your trucks running at peak performance. An on-board diagnostic system controls critical lift truck functions while making it easy to troubleshoot the system using a laptop.

Ground Speed Control

This feature allows you to customize the maximum travel speed of the truck to meet your application requirements without affecting overall performance. The benefits include reduced risk to pedestrian traffic, lower operating costs, enhanced engine wear protection, as well as reduced risk of damaging loads, racks and trucks.



Productive And Durable

This truck is equipped with powerful fuel-injected purePOWER™ gasoline, LP and diesel engines providing the horsepower and torque you need for the most challenging applications. Our engines are environmentally friendly and meet or exceed EPA durability requirements. They are also computer regulated to optimize fuel efficiency. If you're looking for exceptional productivity with maximum fuel efficiency, simply engage the Fuel Saver Mode. This softens the initial acceleration of the truck and reduces fuel consumption by 14 percent while maintaining 95 percent of the truck's overall productivity.

Everything is optimized for performance, including the single-piece, fully cast, drive and steer axles, which protect vital components from damage and contaminants. A unitized frame offers great rigidity for durable performance in tough applications. The drive axle uses a full-floating design to minimize shocks and stresses, easily handling the high loading requirements of the most challenging work environments. A heavy-duty counterweight grill is a standard feature on these trucks.

Premium Performance

A wide array of option packages are available to maximize performance. Premium options such as the integrated side shifter are available for any model. The newly designed side shifter offers excellent lifting capacity while ensuring a clear view of the work area. Ask your Cat® lift truck dealer for more information.

Heavy-Duty Mast

Heavy-duty masts are designed and manufactured for lasting, dependable performance. Narrow mast channels and the efficient positioning and routing of chains and hoses help ensure a clear view forward. The truck's low-profile counterweight design provides good visibility to the rear, even with an LP tank in place. The overhead guard cross bar has been eliminated through a design that optimizes strength while improving visibility.

LED Front Work Lights And Rear Combination Lights

Modern LED lighting technology offers extended service life. Brilliant LED front work lights and rear combination lights are more durable than incandescent lights. The standard LED lights are packaged complete with guards.



Specifications

Characteristics				P3000		P3500		PC4000				
1	Capacity	at rated load center		lb	kg	3,000	1,500	3,500	1,750	4,000	2,000	
2		at load center – distance		in	mm	24.0	500	24.0	500	24.0	500	
3	Power	electric, diesel, gasoline, LP gas				gasoline/LP gas		gasoline/LP gas		gasoline/LP gas		
4	Tire type	cushion, pneumatic				pneumatic		pneumatic		pneumatic		
5	Wheels (x=driven)	number front / rear				2x /2		2x /2		2x /2		
Dimensions				P3000		P3500		PC4000				
10	Lift	maximum fork height with rated load		in	mm	162	4,120	162	4,120	162	4,130	
11	Lift with standard two-stage mast	maximum fork height		in	mm	130	3,320	130	3,320	131	3,330	
12		free fork height		in	mm	4.5	115	4.5	115	4.5	115	
13	Forks	thickness x length x width				1.4 x 3.9 x 42		35 x 100 x 1,070		1.6 x 4 x 42		
	Fork spacing	out-to-out minimum / maximum				200 / 920		200 / 920		200 / 920		
	Tilt	forward / backward		in	mm	7.9 / 36.2		7.9 / 36.2		7.9 / 36.2		
14		length to fork face		deg		6° / 10°		6° / 10°		6° / 10°		
15	Overall Dimensions	width			in	mm	89.0	2,260	90.0	2,295	92.5	2,350
16			with standard tires	in	mm	42.0	1,065	42.0	1,065	42.0	1,065	
17		w/ optional duals	in	mm	N/A	N/A	N/A	N/A	N/A	N/A		
18		with lowered mast	in	mm	N/A	N/A	N/A	N/A	N/A	N/A		
19		seat height	in	mm	84.5	2,140	84.5	2,140	84.5	2,140		
20		to top of overhead guard	in	mm	38.0	959	38.0	959	38.0	959		
21	height	with extended mast		in	mm	83.0	2,100	83.0	2,100	83.0	2,100	
22	Minimum outside turning radius			in	mm	77.0	1,950	78.0	1,980	79.5	2,020	
23	Load moment constant			in	mm	15.7	400	15.7	400	16.3	415	
	Minimum aisle – 90° stack – zero clearance w/out load			in	mm	96.5	2,450	97.5	2,480	100	2,540	
Performance				P3000		P3500		PC4000				
40	Speeds	travel loaded / empty		mph	km/h	11.0 / 12.0	17.5 / 19.0	11.0 / 11.5	17.5 / 19.0	11.0 / 11.5	18.0 / 18.5	
41		lift speed loaded / empty		fpm	mm/s	120 / 125	620 / 630	120 / 125	620 / 630	120 / 125	620 / 630	
42		lowering speed loaded / empty		fpm	mm/s	98 / 98	500 / 500	98 / 98	500 / 500	98 / 98	500 / 500	
43	Drawbar pull	loaded (60 min. rating)		lb	N	3,575	15,900	3,550	15,700	3,450	15,400	
		loaded maximum (5 min. rating)		lb	N	4,125	18,300	4,100	18,200	4,000	17,800	
44	Gradeability	loaded at 1 mph (1.6 km)		%		40.0		39.0		33.0		
		maximum loaded/empty		%		40.1 / 18.4		39.7 / 16.0		38.8 / 14.4		
Weight				P3000		P3500		PC4000				
50	Empty			lb	kg	5,500	2,500	6,000	2,700	6,600	3,000	
51	Axle load	with rated load front / rear (est.)		lb	kg	7,900 / 960	3,575 / 440	8,700 / 1,140	3,925 / 520	9,600 / 1,410	4,375 / 640	
		without load front / rear (est.)		lb	kg	2,430 / 3,075	1,110 / 1,400	2,330 / 3,625	1,060 / 1,650	2,350 / 4,275	1,070 / 1,950	
Chassis				P3000		P3500		PC4000				
60	Tire size	front, standard		in		6.50 x 10-10PR		6.50 x 10-10PR		6.50 x 10/5.00 Solid		
		front, optional duals		in		N/A		N/A		N/A		
61		rear		in		5.0 x 8-8PR		5.0 x 8-8PR		5.00 x 8/3.00 Solid		
62	Wheel base			in	mm	55.0	1,400	55.0	1,400	55.0	1,400	
63	Tread width	front, standard tires		in	mm	35.0	889	35.0	889	35.0	889	
		front, optional duals		in	mm	NA	NA	NA	NA	NA	NA	
64		rear tires		in	mm	35.5	901	35.5	901	35.5	901	
65	Ground clearance	at lowest point at mast		in	mm	4.3	110	4.3	110	4.3	110	
66		at center of wheel base		in	mm	5.9	150	5.9	150	5.9	150	
67		service										
68	Brakes	parking		type		foot-operated, hydraulic		foot-operated, hydraulic		foot-operated, hydraulic		
				type		hand-operated, mechanical		hand-operated, mechanical		hand-operated, mechanical		
Electrical				P3000		P3500		PC4000				
80	Engine	model				K21		K21		K21		
81		continuous output S.A.E. gross		HP	kW	54.5	41.0	54.5	41.0	54.5	41.0	
				at r.p.m.		2,875		2,875		2,875		
82		maximum torque S.A.E. gross		lb-ft	Nm	110	150	110	150	110	150	
			at r.p.m.		1,600		1,600		1,600			
83	cylinder / displacement		cu in	cm ³	126	2,065	126	2,065	126	2,065		
84	Transmission	type				Powershift		Powershift		Powershift		
85		number of speeds forward / reverse				1 / 1		1 / 1		1 / 1		
86	Relief pressure	for attachments at main		psi	bar	2,625	185	2,625	185	2,625	185	
87	Noise level	mean value at operator's ear Leq		dB(A)		73.5		73.5		73.5		

NOTE: These specifications assume the use of drive axles, tires and tilt angles specified. Any modification to specifications, or any other combination of specifications made after the shipment of the truck, requires prior written approval from Mitsubishi Caterpillar Forklift America Inc. ("MCFA"). (See ANSI/ITSDF B56.1.) Also be advised that overall operating visibility may be affected by the mast configuration and mast options of your truck. Therefore, you may need to add ancillary (auxiliary) devices or modify your operating practices. Consult your dealer for further information.

P4000		P4000-D		P5000		P5000-D		P5500		P5500-D	
4,000	2,000	4,000	2,000	5,000	2,500	5,000	2,500	5,500	2,800	5,500	2,800
24.0	500	24.0	500	24.0	500	24.0	500	24.0	500	24.0	500
gasoline/LP gas		diesel		gasoline/LP gas		diesel		gasoline/LP gas		diesel	
pneumatic		pneumatic		pneumatic		pneumatic		pneumatic		pneumatic	
2x / 2		2x / 2		2x / 2		2x / 2		2x / 2		2x / 2	
P4000		P4000-D		P5000		P5000-D		P5500		P5500-D	
162	4,140	162	4,140	162	4,140	162	4,140	178	4,540	178	4,540
131	3,340	131	3,340	131	3,340	131	3,340	130	3,310	130	3,310
5.5	140	5.5	140	5.7	145	5.7	145	5.9	150	5.9	150
1.6 x 4 x 42	40 x 100 x 1,070	1.6 x 4 x 42	40 x 100 x 1,070	1.6 x 4 x 42	40 x 100 x 1,070	1.6 x 4 x 42	40 x 100 x 1,070	1.8 x 5 x 42	45 x 100 x 1,070	1.8 x 5 x 42	45 x 100 x 1,070
8.7 / 39.4	220 / 1,000	8.7 / 39.4	220 / 1,000	8.7 / 39.4	220 / 1,000	8.7 / 39.4	220 / 1,000	9.8 / 39.4	250 / 1,000	9.8 / 39.4	250 / 1,000
6° / 10°		6° / 10°		6° / 10°		6° / 10°		6° / 10°		6° / 10°	
98.0	2,490	98.0	2,490	100	2,550	100	2,550	104	2,645	104	2,645
45.5	1,150	45.5	1,150	45.5	1,150	45.5	1,150	50.0	1,275	50.0	1,275
64.5	1,640	64.5	1,640	64.5	1,640	64.5	1,640	67.5	1,715	67.5	1,715
84.5	2,140	84.5	2,140	84.5	2,140	84.5	2,140	85.5	2,170	81.0	2,045
38.0	968	38.0	968	38.0	968	38.0	968	40.0	1,018	40.0	1,018
83.0	2,105	83.0	2,105	83.0	2,105	83.0	2,105	84.0	2,125	84.0	2,125
180	4,570	180	4,570	180	4,570	180	4,570	180	4,540	180	4,540
86.5	2,200	86.5	2,200	88.0	2,230	88.0	2,230	91.0	2,315	91.0	2,315
17.9	455	17.9	455	17.9	455	17.9	455	19.3	490	19.3	490
104.4	2,655	104.4	2,655	105.9	2,685	105.9	2,685	110.3	2,805	110.3	2,805
P4000		P4000-D		P5000		P5000-D		P5500		P5500-D	
10.5 / 11.5	17.0 / 18.5	10.0 / 11.0	16.5 / 18.0	10.5 / 11.5	17.0 / 18.5	10.0 / 11.0	16.5 / 17.5	10.5 / 11.0	17.0 / 18.0	10.0 / 11.0	16.0 / 17.5
125 / 130	630 / 650	120 / 125	610 / 640	125 / 130	630 / 650	120 / 125	610 / 640	99 / 100	500 / 520	96 / 100	490 / 510
98 / 98	500 / 500	98 / 98	500 / 500	98 / 98	500 / 500	98 / 98	500 / 500	98 / 98	500 / 500	98 / 98	500 / 500
4,225	18,800	4,000	18,800	4,175	18,600	3,950	17,600	4,175	18,500	3,900	17,300
4,800	21,300	4,475	19,900	4,750	21,100	4,425	19,600	4,750	21,100	4,350	19,400
39.0		36.0		33.0		30.0		29.0		26.0	
40.2 / 18.8		40.4 / 18.7		37.8 / 16.4		34.2 / 16.4		33.0 / 16.9		29.7 / 16.9	
P4000		P4000-D		P5000		P5000-D		P5500		P5500-D	
7,300	3,300	7,500	3,425	7,900	3,600	8,100	3,700	9,100	4,125	9,300	4,225
10,200 / 1,450	4,650 / 660	10,300 / 1,590	4,700 / 720	12,000 / 1,470	5,400 / 670	12,100 / 1,620	5,500 / 740	13,400 / 1,700	6,100 / 770	13,500 / 1,840	6,100 / 840
3,200 / 4,075	1,460 / 1,850	3,300 / 4,225	1,500 / 1,920	3,175 / 4,775	1,440 / 2,170	3,250 / 4,925	1,480 / 2,230	3,650 / 5,400	1,660 / 2,460	3,725 / 5,600	1,700 / 2,530
P4000		P4000-D		P5000		P5000-D		P5500		P5500-D	
7.0 x 12-12PR		7.0 x 12-12PR		7.0 x 12-12PR		7.0 x 12-12PR		28 x 9 x 15-12PR		28 x 9-15-12PR	
7.0 x 12-12PR		7.0 x 12-12PR		7.0 x 12-12PR		7.0 x 12-12PR		28 x 9 x 15-12PR		28 x 9-15-12PR	
6.00 x 9-10PR		6.00 x 9-10PR		6.00 x 9-10PR		6.00 x 9-10PR		6.50 x 10-10PR		6.50 x 10-10PR	
63.0	1,600	63.0	1,600	63.0	1,600	63.0	1,600	64.0	1,620	64.0	1,620
38.0	961	38.0	961	38.0	961	38.0	961	42.0	1,061	42.0	1,061
47.5	1,205	47.5	1,205	47.5	1,205	47.5	1,205	47.5	1,201	47.5	1,201
38.5	978	38.5	978	38.5	978	38.5	978	38.5	981	38.5	981
4.6	117	4.6	117	4.6	117	4.6	117	5.4	136	5.4	136
6.3	159	6.3	159	6.3	159	6.3	159	7.0	178	7.0	178
foot-operated, hydraulic		foot-operated, hydraulic		foot-operated, hydraulic		foot-operated, hydraulic		foot-operated, hydraulic		foot-operated, hydraulic	
hand-operated, mechanical		hand-operated, mechanical		hand-operated, mechanical		hand-operated, mechanical		hand-operated, mechanical		hand-operated, mechanical	
P4000		P4000-D		P5000		P5000-D		P5500		P5500-D	
K25		S4S		K25		S4S		K25		S4S	
63.0	46.9	59.0	44.1	63.0	46.9	59.0	44.1	63.0	46.9	59.0	44.1
2,700		2,300		2,700		2,300		2,700		2,300	
139	188	135	183	139	188	135	183	139	188	135	183
1,600		1,800		1,600		1,800		1,600		1,800	
152	2,490	203	3,330	152	2,490	203	3,330	152	2,490	203	3,330
Powershift		Powershift		Powershift		Powershift		Powershift		Powershift	
1 / 1		1 / 1		1 / 1		1 / 1		1 / 1		1 / 1	
2,625	185	2,625	185	2,625	185	2,625	185	2,625	185	2,625	185
76.5		75.5		76.5		75.5		76.5		75.5	

P6000		P6000-D		P6500		P6500-D		P7000		P7000-D	
6,000	3,000	6,000	3,000	6,500	3,300	6,500	3,300	7,000	3,500	7,000	3,500
24.0	500	24.0	500	24.0	500	24.0	500	24.0	500	24.0	500
gasoline/LP gas		diesel		gasoline/LP gas		diesel		gasoline/LP gas		diesel	
pneumatic		pneumatic		pneumatic		pneumatic		pneumatic		pneumatic	
2x /2		2x /2		2x /2		2x /2		2x /2		2x /2	
P6000		P6000-D		P6500		P6500-D		P7000		P7000-D	
171	4,360	171	4,360	179	4,550	179	4,550	179	4,550	179	4,550
130	3,310	130	3,310	131	3,350	131	3,350	131	3,350	131	3,350
5.9	150	5.9	150	5.9	150	5.9	150	5.9	150	5.9	150
1.8 x 5 x 42	45 x 100 x 1,070	1.8 x 5 x 42	45 x 100 x 1,070	2 x 5 x 42	50 x 125 x 1,070	2 x 5 x 42	50 x 125 x 1,070	2 x 5 x 42	50 x 125 x 1,070	2 x 5 x 42	50 x 125 x 1,070
9.8 / 39.4	250 / 1,000	9.8 / 39.4	250 / 1,000	9.8 / 39.4	250 / 1,000	9.8 / 39.4	250 / 1,000	9.8 / 39.4	250 / 1,000	9.8 / 39.4	250 / 1,000
6° / 10°		6° / 10°		6° / 10°		6° / 10°		6° / 10°		6° / 10°	
107	2,720	107	2,720	108	2,750	108	2,750	110	2,790	110	2,790
50.0	1,275	50.0	1,275	50.0	1,275	50.0	1,275	51.0	1,290	51.0	1,290
67.5	1,715	67.5	1,715	67.5	1,715	67.5	1,715	67.5	1,715	67.5	1,715
85.5	2,170	85.5	2,170	85.5	2,170	85.5	2,170	91.0	2,300	91.0	2,500
40.0	1,018	40.0	1,018	40.0	1,018	40.0	1,018	40.0	1,018	40.0	1,018
84.0	2,125	84.0	2,125	84.0	2,125	84.0	2,125	84.5	2,140	84.5	2,140
179	4,540	179	4,540	180	4,540	180	4,540	180	4,570	180	4,570
94.0	2,380	94.0	2,380	96.0	2,430	96.0	2,430	96.0	2,440	96.0	2,440
19.3	490	19.3	490	19.3	490	19.3	490	19.3	490	19.3	490
113.3	2,870	113.3	2,870	115.3	2,920	115.3	2,920	115.3	2,930	115.3	2,930
P6000		P6000-D		P6500		P6500-D		P7000		P7000-D	
10.5 / 11.0	17.0 / 18.0	10.0 / 11.0	16.0 / 17.5	11.0 / 11.5	17.5 / 18.5	10.5 / 11.5	16.5 / 18.0	11.0 / 11.5	17.5 / 18.5	10.0 / 11.5	16.5 / 18.0
99 / 100	500 / 520	96 / 100	490 / 510	99 / 100	500 / 520	96 / 100	490 / 510	83 / 86	420 / 440	80 / 85	410 / 430
98 / 98	500 / 500	98 / 98	500 / 500	98 / 98	500 / 500	98 / 98	500 / 500	98 / 98	500 / 500	98 / 98	500 / 500
4,150	18,400	3,875	17,200	3,975	17,700	3,700	16,400	3,950	17,600	3,675	16,300
4,725	21,000	4,325	19,300	4,500	20,100	4,134	18,400	4,489	20,000	4,110	18,300
27.0		25.0		23.7		21.7		22.5		20.6	
30.9 / 17.3		27.7 / 17.3		27.1 / 17.3		24.3 / 17.3		25.8 / 14.8		23.2 / 14.9	
P6000		P6000-D		P6500		P6500-D		P7000		P7000-D	
9,300	4,250	9,600	4,350	10,000	4,575	10,300	4,675	10,200	4,650	10,500	4,775
14,300 / 1,670	6,500 / 760	14,400 / 1,810	6,500 / 820	15,100 / 2,130	6,900 / 970	15,200 / 2,270	6,900 / 1,030	15,900 / 2,060	7,200 / 930	16,000 / 2,200	7,300 / 1,000
3,825 / 5,500	1,730 / 2,525	3,900 / 5,700	1,780 / 2,575	3,750 / 6,300	1,700 / 2,875	3,825 / 6,400	1,740 / 2,925	3,675 / 6,600	1,670 / 2,975	3,775 / 6,700	1,720 / 3,050
P6000		P6000-D		P6500		P6500-D		P7000		P7000-D	
28 x 9-15-12PR		28 x 9-15-12PR		28 x 9-15-12PR		28 x 9-15-12PR		250 x 15-16PR		250 x 15-16PR	
28 x 9-15-12PR		28 x 9-15-12PR		28 x 9-15-12PR		28 x 9-15-12PR		250 x 15-16PR		250 x 15-16PR	
6.50 x 10-10PR		6.50 x 10-10PR		6.50 x 10-10PR		6.50 x 10-10PR		6.50 x 10-12PR		6.50 x 10-12PR	
67.0	1,700	67.0	1,700	67.0	1,700	67.0	1,700	67.0	1,700	67.0	1,700
42.0	1,061	42.0	1,061	42.0	1,061	42.0	1,061	42.0	1,061	42.0	1,061
47.5	1,201	47.5	1,201	47.5	1,201	47.5	1,201	47.5	1,201	47.5	1,201
38.5	981	38.5	981	38.5	981	38.5	981	38.5	981	38.5	981
5.4	136	5.4	136	5.4	136	5.4	136	5.4	136	5.4	136
7.0	178	7.0	178	7.0	178	7.0	178	7.0	178	7.0	178
foot-operated, hydraulic		foot-operated, hydraulic		foot-operated, hydraulic		foot-operated, hydraulic		foot-operated, hydraulic		foot-operated, hydraulic	
hand-operated, mechanical		hand-operated, mechanical		hand-operated, mechanical		hand-operated, mechanical		hand-operated, mechanical		hand-operated, mechanical	
P6000		P6000-D		P6500		P6500-D		P7000		P7000-D	
K25		S4S		K25		S4S		K25		S4S	
63.0	46.9	59.0	44.1	63.0	46.9	59.0	44.1	63.0	46.9	59.0	44.1
2,700		2,300		2,700		2,300		2,700		2,300	
139	188	135	183	139	188	135	183	139	188	135	183
1,600		1,800		1,600		1,800		1,600		1,800	
152	2,490	203	3,330	152	2,490	203	3,330	152	2,490	203	3,330
Powershift		Powershift		Powershift		Powershift		Powershift		Powershift	
1 / 1		1 / 1		1 / 1		1 / 1		1 / 1		1 / 1	
2,625	185	2,625	185	2,625	185	2,625	185	2,625	185	2,625	185
76.5		75.5		76.5		75.5		76.5		75.5	

Call-out numbers shown in the diagram correspond to the first column of the specifications chart.

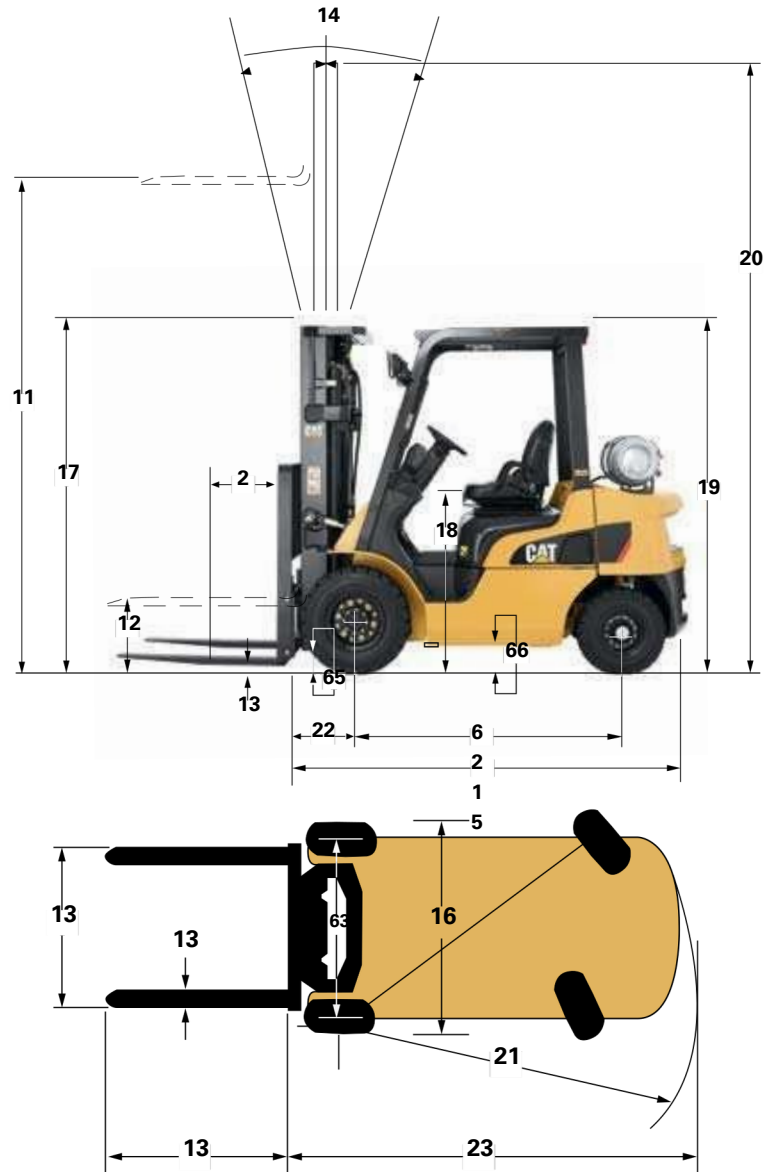

Safety Standards

These trucks meet American National Standards Institute/Industrial Truck Standards Development Foundation, ANSI/ITSDF B56.1.

UL-Classified by Underwriters Laboratories, Inc., as to fire and electric shock hazard only. Availability: Types G, LP and D standard. Types GS, LPS and DS optional. Users should be aware of, and adhere to, applicable codes and regulations regarding operator training, use, operation, and maintenance of powered industrial trucks, including:

Contact your Cat lift truck dealer for further information including operator training programs and auxiliary visual and audible warning systems, fire extinguishers, etc., as available for specific user applications and requirements. Specifications, equipment, technical data, photos and illustrations based on information at time of printing and subject to change without notice. Some products may be shown with optional equipment.



Quality

Reliability

Customer Service



Internal Combustion Pneumatic Tire Lift Trucks

CAT[®] Lift Trucks

1-800-CAT-LIFT

www.cat-lift.com